

FP - PAD

Is useful under equipment of all speeds.
To minimize transmission of disturbances from entering floor.

ALL SPEEDS

Prevents equipments rocking by compensating for mismatch of 4 rigid support points to typical wavy floor surface:

- EQUIPMENT w/4 rigid support points.
- COMPRESSOR (TANK MOUNTED)

HIGH SPEED 1500 CPM AND UP

FP- PAD eliminates noise and reduces vibration transmitted from:

- ENGINES
- TRANSFORMERS
- PUMPS and PIPING
- STEAM GENERATORS
- CRUSHERS

LOW SPEED 0 TO 250 CPM

FP - PAD limits impact shock transmission and simplifies installation of:

- PUNCH PRESSES
- SHEARS
- VACUUM PUMPS
- HAMMERS

FP - PAD

Is useful under equipment to minimize transmission of disturbances from the floor.

**LOW SPEED AND HIGH SPEED
0 TO 250 CPM & 1500 CPM & UP**

FP -PAD protects these sensitive instruments, machine and devises from low frequency shocks and high frequency vibrations present in the floor:

- GRINDERS
- SURFACE PLATES
- MACHINE TOOLS
- INSTRUMENTS

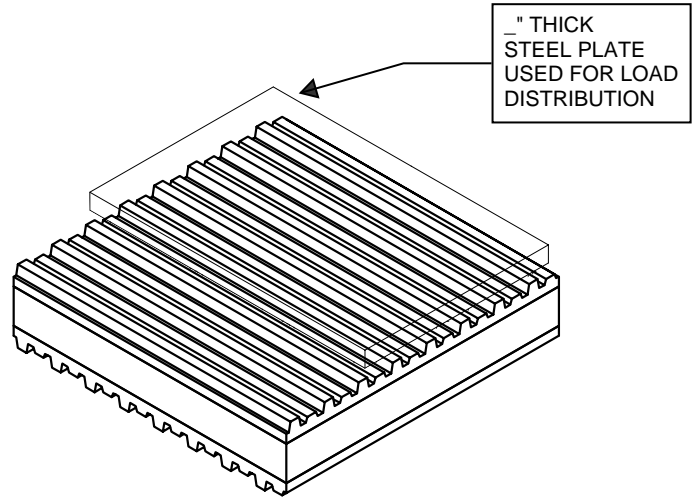

LOAD CAPACITY

Load capacity to 60 lbs/SQ. inch.

THICKNESS

Standard thickness 1" others are available.

NON - SKID

Thread surfaces resist "Walking"

DURABLE

Material is ozone resistant Neoprene Rubber blend and Cork.

MAXIMUM PAD SIZE 36" x 36" FACTORY CUT SIZES LISTED							
STANDARD CAPACITY							
SIZE (Inches)	Max. Load Selection At 40 P.S.I.	SIZE (Inches)	Max. Load Selection At 40 P.S.I.	SIZE (Inches)	Max. Load Selection At 40 P.S.I.	SIZE (Inches)	Max. Load Selection At 40 P.S.I.
2 x 2	160	3 x 3	360	6 x 6	1440	12 x 12	5760
2 x 3	240	3 x 6	720	6 x 9	2160	12 x 18	8640
2 x 4	320	3 x 9	1080	6 x 12	2880	12 x 24	11520
2 x 6	480	3 x 12	1440	6 x 18	4320	12 x 36	17280
2 x 12	960	3 x 18	2160	6 x 36	6480		
2 x 18	1440	3 x 24	2880			18 x 18	12960
2 x 24	1920	3 x 36	4320	9 x 9	2880	18 x 24	17280
2 x 36	2880			9 x 12	4320	18 x 36	25920
		4 x 4	640	9 x 18	6480		
		4 x 6	960			24 x 24	23040
		4 x 9	1440			24 x 36	35560
		4 x 12	1920				
		4 x 18	2880			36 x 36	51840
		4 x 36	5760				



CALIFORNIA DYNAMICS CORPORATION
20500 PRAIRIE ST. CHATSWORTH CA, 91311
Phone 323-223-3882
Email: caldyn@caldyn.com

"CALL US - TO SET THINGS RIGHT"

JOB: _____

CUSTOMER: _____

TAG: _____

Dwg. No.
F260

Date

PREP By: _____

Date

CHKD By: _____

Date

DO NOT SCALE DRAWING

TYPE

FP

1" RIBBED SANDWICH PAD

RIBBED NEOPRENE AND CORK