

SECTION A-A

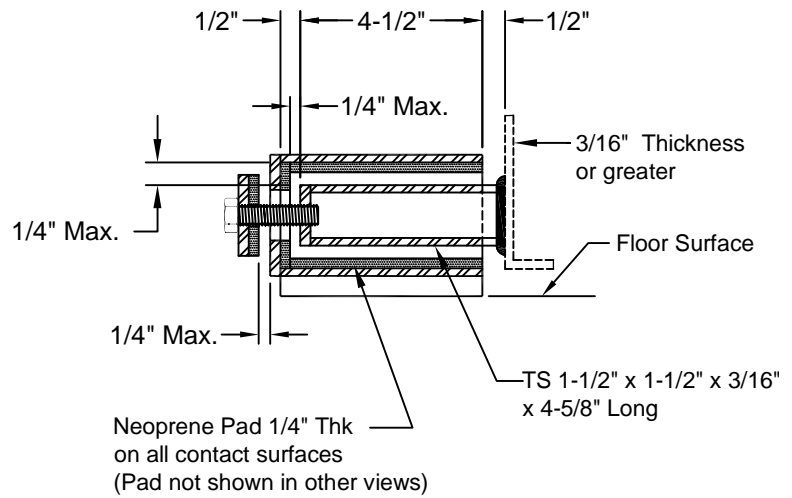

Direction	Restraint Rating (Lbs.)
Anchor Bolts Line Rating	3300
Perpendicular to A. Bolts Line Rating	3300
Vertical Rating	3300

Notes:
All dimensions in inches.

Installation Instructions
See file F58

ALLOWABLE STRESS DESIGN

$$F_p \quad F_p = \frac{.4 * a_p * S_{ds}}{R_p / I_p} \left(1 + 2 \frac{z}{h} \right)$$

Where :
 $a_p = 2.5$ (Isolated), $R_p = 2.0$ (Isolated), $I_p = 1.5$ (Hospital)

Except that:

F_p shall not be less than $.3 S_{ds} I_p W_p$ and need not be more than $1.6 S_{ds} I_p W_p$ and $F_p = .7 F_p$ (ASCE 7-05, 13.1.7 ASD)

NOTES:

1. RLC Maximum clearance not greater than 1/4" inch
Design force may be taken as F_p per ASCE 7-05 Table 13.6-1 footnote b.



CALIFORNIA DYNAMICS CORPORATION
5572 ALHAMBRA AVE. LOS ANGELES CA, 90032
PH. 323-223-3882 FAX. 323-223-7941
email: caldyn@earthlink.net

"CALL US - TO SET THINGS RIGHT"

Assoc. Member



JOB: _____
CUSTOMER: _____
TAG: _____

Dwg. No. F122	Date 10/11/16
PREP By:	Date
CHKD By:	Date
DO NOT SCALE DRAWING	

TYPE
RL-C
SEISMIC RESTRAINT
CALIFORNIA
PRE-APPROVED
OPA-0070-10